

The eBike Display
Users Manual

KD51C-U

Contents

| | |
|---|----|
| Product Name and Model..... | 1 |
| Specifications..... | 1 |
| Appearance and Size..... | 1 |
| Function Summary..... | 2 |
| ◆Function Summary..... | 2 |
| ◆Functional Area Distribution..... | 3 |
| General Operation..... | 3 |
| ◆Switching the E-bike System On/Off..... | 3 |
| ◆Display Interface..... | 3 |
| ◆Switching Push-Assist Mode On/Off..... | 4 |
| ◆Switching the Lighting On/Off..... | 4 |
| ◆Assist Level Selection..... | 5 |
| ◆Battery Indicator..... | 5 |
| ◆Motor Power Indicator..... | 5 |
| ◆Error Code Indication..... | 6 |
| General Settings..... | 6 |
| ◆Trip Distance Clearance..... | 6 |
| ◆Backlight Contrast Settings..... | 7 |
| ◆Unit km/mi Conversion..... | 7 |
| General Parameter Settings..... | 7 |
| ◆Wheel Diameter Settings..... | 8 |
| ◆Speed-limit Settings..... | 8 |
| Personalized Parameter Settings..... | 8 |
| ◆Battery Power Bar Settings..... | 9 |
| ◆Assist Level Settings (optional)..... | 9 |
| PAS Ratio Settings..... | 10 |
| ◆Controller Over-current Cut Settings (optional)..... | 10 |
| ◆Power Assistant Sensor Settings(optional)..... | 11 |
| The Direction of PAS Settings..... | 11 |
| The Sensitivity of PAS Settings..... | 11 |
| ◆Magnet Quantity Settings..... | 12 |
| ◆Speed Sensor (optional)..... | 12 |
| ◆Throttle Definition (optional)..... | 12 |

| | |
|---|----|
| Throttle Push-Assist Enable/Disable..... | 12 |
| Throttle Level Enable/Disable..... | 13 |
| System Settings (optional)..... | 13 |
| ◆ Delay Time Settings of Battery Power..... | 13 |
| ◆ Max Speed Limited..... | 14 |
| ◆ Push-Assist Enable/Disable..... | 14 |
| ◆ Slow Start Up Settings..... | 15 |
| ◆ Power-on Password Settings..... | 15 |
| ◆ Power-on Password Enable/Disable..... | 15 |
| ◆ Power-on Password Modify..... | 16 |
| ◆ Exit Settings..... | 16 |
| Recover Default Settings..... | 17 |
| Quality Assurance and Warranty Scope..... | 17 |
| I Warranty..... | 17 |
| II Others..... | 17 |
| Connection Layout..... | 18 |
| Warnings..... | 18 |

Product Name and Model

Intelligent LCD display of E-bike
Model: KD51C.

Specifications

- Rated voltage: 24V/36V/48V
- Rated working current: 10mA
- Maximum working current: 30mA
- Off-state leakage current: <1uA
- Operating temperature: -20°C~ 60°C
- Storage temperature: -30°C~ 70°C

Appearance and Size

Product appearance and dimensional drawing (unit: mm)

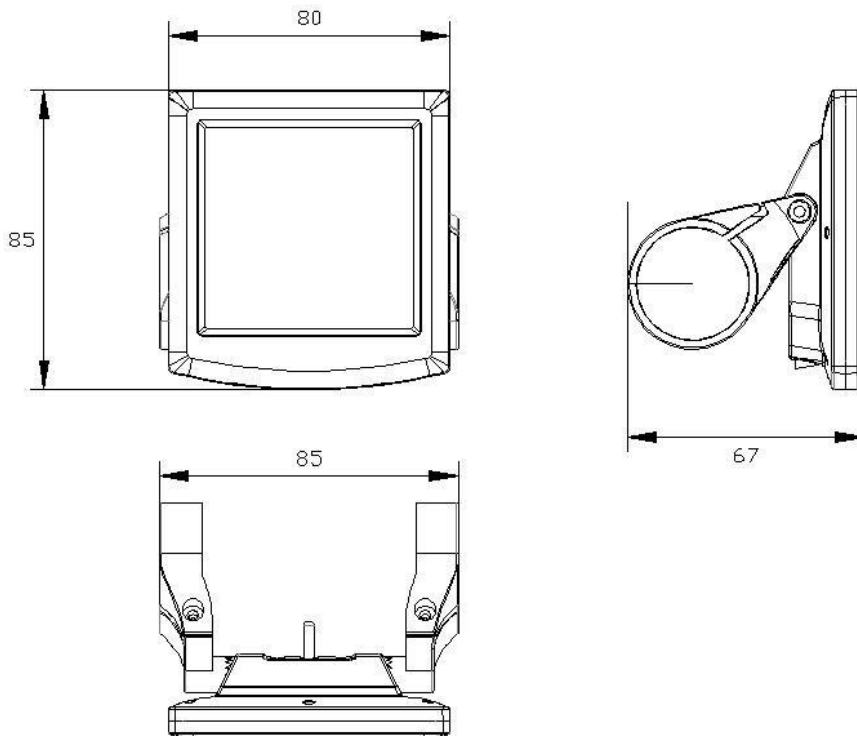

Remote appearance and dimension (unit: mm)

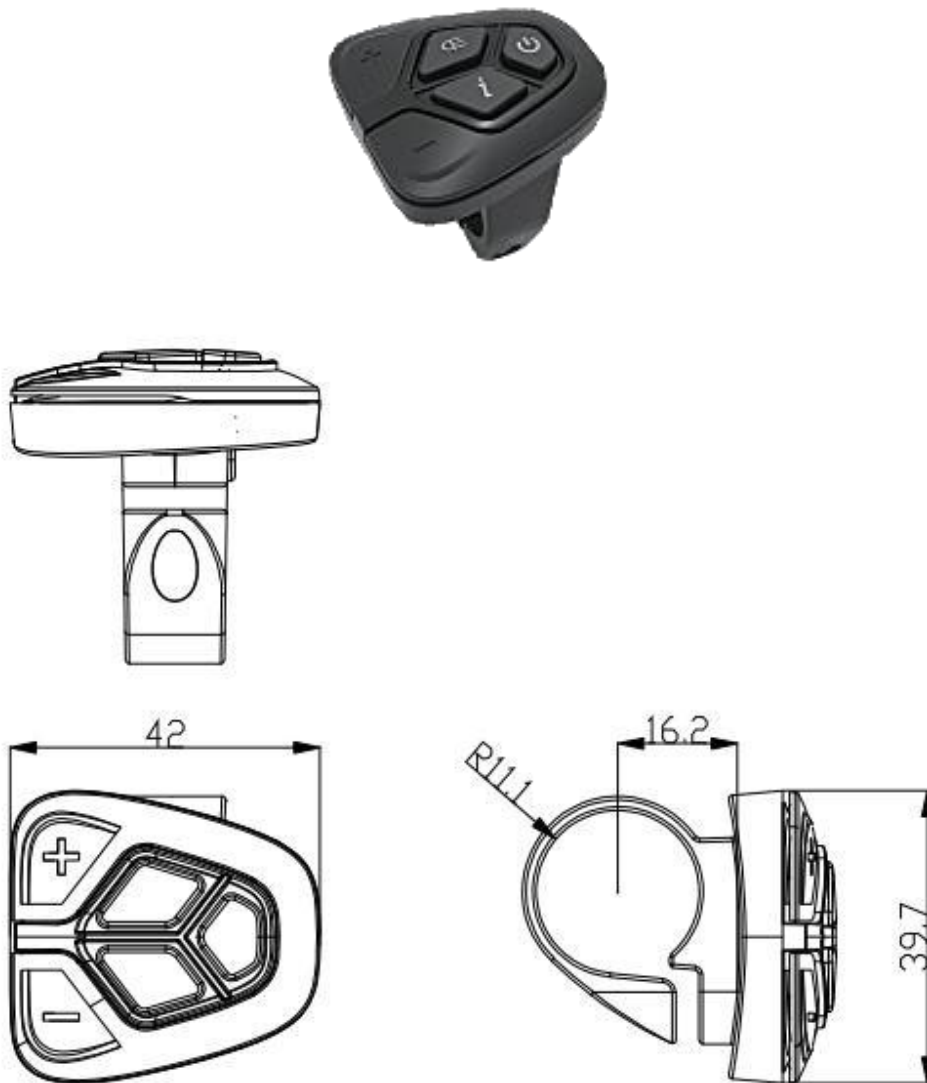

Function Summary

◆Function Summary

KD51C has many functions to meet the bikers' needs. The indicating contents are as follows:

- Smart battery indicator
- Assist-level indication
- Speed indication (incl. running speed, max. speed and average speed)
- ODO meter and trip distance
- The push-Assist function
- Trip time indication
- The lighting On/Off

- Error code indication
- Motor-output indication (optional)
- Pedaling frequency indication (optional)
- The remaining range indication (optional)
- Various parameters settings (e.g., wheel size, speed-limited, battery level bar, Assist level, controller limited current, max speed, password enable, etc.)
- Recover default settings

◆**Functional Area Distribution**

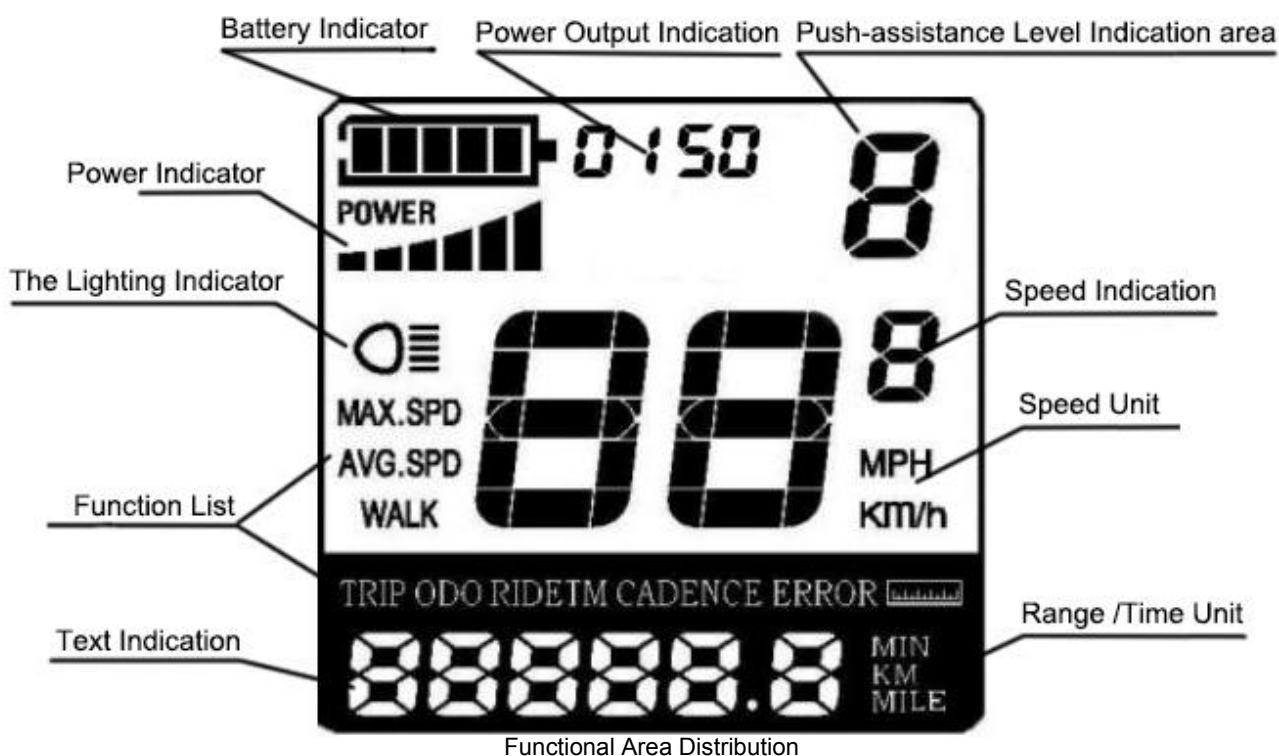

General Operation

◆**Switching the E-bike System On/Off**

Press the power button to switch on the E-bike system. Hold the power button for 2s, the E-bike system will be switched off.

When E-bike system is switched off, the leakage current is less than 1μA.

■ When the E-bike is parked for more than 10 minutes, E-bike system will be switched off automatically.

◆**Display Interface**

After switching on the E-bike system, the display will show Speed and Total Distance. Pressing the “i” button will show more riding data as follows: Current Speed (Km/h) → Avg. Speed (Km/h) → Max. Speed (Km/h) → Trip Distance (Km) → Total Distance (Km) → Trip Time (Min.).

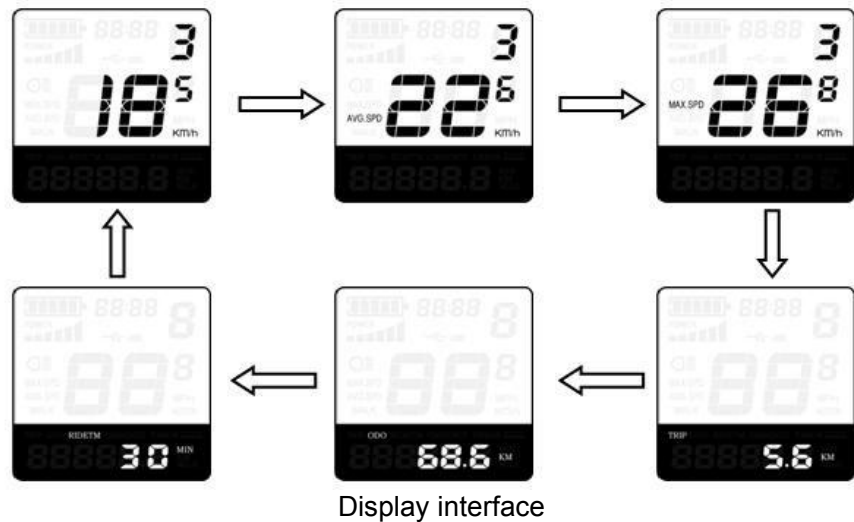

◆ Switching Push-Assist Mode On/Off

To activate the push-Assist function, keep holding the “-” button. The E-bike’s is activated to go at a uniform speed of 6 Km/h while ‘WALK’ is shown on the display screen.

The push-Assist function is switched off as soon as you release the “-” button on the operating unit.



Push-Assist Mode

■ Push-Assist function may only be used when pushing the E-bike. Be aware of danger of injury when the wheels of the E-bike do not have ground contact while use the push- Assist function.

◆ Switching the Lighting On/Off

To switch on the lights (headlights, taillights and display backlight), press the “☰” button. Likewise, press the “☰” button again; the lights can be switched off.

If the headlights or taillights are independent of “☰” button, the “☰” button can only be used as display backlight switch.



Switch the Lighting On/Off Interface

◆ Assist Level Options

The level of Assist of the E-bike drive when pedaling can be adjusted via the display. The Assist level can be changed anytime, even during riding.

The default Assist level ranges from level “0” to level “5”.The output power is zero on Level “0”. Level “1” is the minimum power. Level “5” is the maximum power.

To increase the Assist level, press the “+” button until the desired Assist level is displayed; to decrease the Assist level, press the “-” button. The default value is level ‘1’



Assist Level “5”

◆ Battery Indicator

The five battery bars represent the capacity of the battery. Each bar is equivalent to a capacity of approx. 20% battery power. When the battery is in low voltage, battery frame will flash to give a notice that the battery needs to be recharged immediately.



Battery Indicator

◆ Motor Power Indicator

The power of the motor can be read via below interface.



Motor Power Indication

◆USB Connection Indicator

The external devices can be charged by the display by using a matching USB cable to connect the display USB port to a smart-phone or similar devices. (5V charging voltage and max 1 A charging current).



USB Connection Indicator

◆Error Code Indication

The components of the E-bike system are continuously and automatically monitored. When an error is detected, the respective error code is indicated in text indication area.

Here is the detail message of the error code in **Attached list 1**.



Error Code Indication

■ **Make the display repaired when an error code appears. Or else you will not be able to ride the bike normally.**

General Settings

To access general settings menu, hold both the “+” button and the “-” button for 2s.

■ **All the Settings are operated in the case of a parked bicycle.**

◆Trip Distance Clearance

‘TC’ represents trip distance clearance setting.

To clear trip distance, press the “+” button or the “-” button until the Y is displayed.

To store a changed setting, press the “i” button and then access backlight settings.



Trip Distance Clearance Settings Interface

◆Backlight Contrast Settings

'bL' represents backlight settings. Level "1" is the low brightness, Level "2" is the medium brightness, and Level "3" is high brightness. The default level is "1".

To modify the backlight brightness, press the "+" button or the "-" button to choose the desired setting value.

To store a changed setting, press the "i" button and then access the unit Conversion Settings.



Backlight Brightness Settings Interface

◆Unit km/mi Conversion

'U' represents unit settings, "1" is mile and "2" is kilometer. The default value is "2".

To convert unit, press the "+" button or the "-" button to choose the desired setting item, and then press the "i" button to confirm.

To store a changed setting, press the "i" button and then access trip distance clearance settings.

To store a changed setting, hold the "i" button for 2s and then exit general settings.



Mile and Kilometer Conversion Settings Interface

General Parameter Settings

To access general parameter Settings interface, hold both the "+" and the "-" button for 2s (**General Settings page**) and hold both "-" and "i" button for 2s.

◆Wheel Diameter Settings

Ld represents wheel diameter settings. Optional values are 16, 18, 20, 22, 24, 26, 700C and 28. The default value is 26 inch.

To change basic settings, press the “+” or the “-” button to increase or decrease until the desired value is displayed.

To store a changed setting, press “i” button. Then access the speed-limit settings interface.



Wheel Diameter Settings Interface

◆Speed-limit Settings

LS represents the limit speed settings. When the current speed is faster than speed limit, the E-bike system will switch off automatically. Speed limit range is 12Km/h to 40Km/h.

The default value is 25Km/h.

To change basic settings, press the “+” or the “-” button to increase or decrease until the desired value is displayed.

To store a changed setting and exit General Parameter Settings, hold the “i” button for 2s.



Limit Speed Settings Interface

Personalized Parameter Settings

Personalized Parameter Settings can meet a variety of individual requirements. **Key-Disp** displays work under different protocols, support the settings of different optional items. There are 8 settings items, such as Battery Power Bar Settings, Power Assistant Level Settings, Over- current Cut Settings, Power Assistant Sensor Settings, Speed Sensor

Settings, Throttle Function Settings, System Settings and Power-on Password Settings.

To access Personalized Parameter Settings page, hold both the “+” and the “-” button for 2s (**General Settings page**) and hold both the “+” and the “-” button for 2s again.

To access the corresponding setting, press the “+” or the “-” button to increase or decrease until the desired item is displayed, and then press the “i” button to confirm.

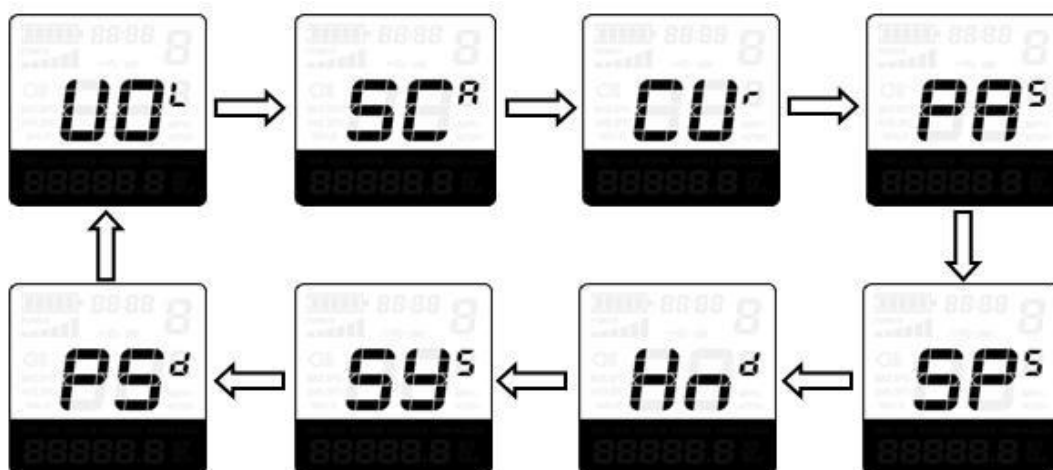

Setting Items Interface

◆ Battery Power Bar Settings

VOL represents voltage settings. Each bar represents a voltage value. 5 bars voltage values must be entered one by one. For example, VOL 1 is first bar voltage value. The default value is 31.5V.

To set battery power bar, press the “+” or the “-” button to increase or decrease the number.

To store a changed setting, press the “i” button and access the second bar. You can set the values for other bars in the same way. After 5 bars voltage values are entered, hold the “i” button to confirm and then return to the previous menu.

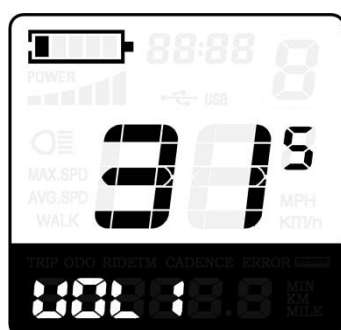

Battery Power Bar Settings

◆ Power Assist Level Settings (optional)

Assist Level Option

‘SCR’ represents power assist level settings. There are 8 modes for your choice: 0-3, 1-3, 0-5, 1-5, 0-7, 1-7, 0-9, 1-9. The default value is 0-5.

To change the mode of Assist-level, press the “+” or the “-” button to choose the desired mode, and then press the “i” button to confirm, and then access the PAS ratio settings page automatically.



PAS Mode Option Interface

PAS Ratio Settings

To change the value of PAS ratio, press the "+" button or "-" button to choose the desired value, and then press the "i" button to confirm

For example, the range is “45-55 percent” for level “1”, ratio value can be modified, and the default value is 50 percent.

To store the modified setting, press the “i” button and turn to the next PAS ratio settings.

After all PAS ratio inputted, hold the “i” button for 2s to confirm and then return to previous menu. Please refer to **Attached list 2**.



PAS Ratio Interface

◆Controller Over-current Cut Settings (optional)

CUR represents controller over-current cut settings. CUR value can be changed from 7.0A to 25.0A. The default value is 15A.

To change basic settings, press the “+” or the “-” button to increase or decrease the value of the current.

To store a changed setting, hold the “i” button and then return to previous menu.



CUR Settings Interface

◆ Power Assistant Sensor Settings (optional)

The Direction of PAS Settings

PAS represents power assistant sensor settings. “run-F” means forward direction, while “run-b” means back direction. The default value is “run-F”.

To change The Direction of Power Assistant Sensor Settings, press “+” or “-” button to select F or b.

To store a changed setting, press “i” button and access PAS sensitivity settings.



Direction of PAS Sensor Settings

The Sensitivity of PAS Settings

SCN represents the sensitivity of PAS settings. The sensitivity value is “2” to “9”. “2” is the strongest, “9” is the weakest. The default value is “2”.

To change the sensitivity of PAS sensor, press “+” or “-” button to select sensitivity value.

To store a changed setting, press the “i” button and then access magnet disk settings mode.



The Sensitivity of PAS Settings

Magnet Quantity Settings

n represents magnet numbers of PAS disk. The default value is 6.

To change magnet numbers of PAS disk, press “+” or “-” button to choose magnet quantity for PAS disk.

To store a changed setting, hold the “i” button and then return to previous menu.



PAS Magnet Disk Settings

◆Speed Sensor (optional)

SPS represents speed sensor settings. The default value is 1

To change speed sensor settings, press the “+” or the “-” button to select the quantity of magnet head (the range is from 1 to 15).

To store a changed setting, hold the “i” button and then return to previous menu.



Speed Sensor Selection

◆Throttle Definition (optional)

Throttle Push-Assist Enable/Disable

HL represents throttle push-Assist function. HL-N represents throttle Assist push

function is disabled. HL-y represents throttle Assist push function is enabled. The default value is N.

To change throttle push-Assist function, press the “+” or the “-” button to select Y.

To store a changed setting, press “i” button. Otherwise, to select N and then access Throttle Level Enable Settings.



Throttle Enable/Disable Interface

Throttle Level Enable/Disable

HF-y represents throttle level enabled, HF-N represents throttle level is disabled. The default value is N.

To change throttle level function, press the “+” or the “-” button to select Y or N and then press the “i” button to confirm, then access Throttle Enable Settings page.

To return to previous menu, hold the “i” button for 2s.



Throttle Level Enable or Disable Interface

◆ System Settings (optional)

Delay Time Settings of Battery Power

DLy represents delay time of battery power settings. The default value is 3s.

To change delay time settings, press the “+” or the “-” button to select delay time 3s, 6s, 12s.

To store a changed setting, press the “i” button and then access the max speed limited.



Delay Time of Battery Power Interface

Max. Speed Limited

LS represents max speed limited settings. The default value is 40Km/h.

To change Max speed limited setting, press the “+” or the “-” button to set the max speed from 25Km/h~40 Km/h.

To store a modified setting, press the “i” button and then access Button PAS Settings.



Max. Speed Limited Settings

- The maximum speed limit is set by display manufacturer.

Push-Assist Button Enable/Disable

PUS represents push-assist button settings. Y represents push-assist button is enabled, N represents push-assist button is disabled. The default value is Y.

To change button push-assist button settings, press the “+” or the “-” button to choose Y or N.

To store a changed setting, press the “i” button and then access Slow Start up settings.



Push-assist button Enable/Disable settings

Slow Start up Settings

SSP represents slowly start up and the range is “1-4”, “4” is the slowest. The default value is “1”.

To change slowly start up settings, press the “+” or the “-” button to select the desired value.

To store a modified setting, press the “i” button and then turn to Delay time settings of battery power page. Hold the “i” button for 2s to return to previous menu.



Slow Start up settings interface

◆Power-on Password Settings

P2, 0000 on the screen means power-on password settings. The password is 1212.

After accessing power-on password settings, press the “+” or the “-” button to modify the value and then press the “i” button to confirm digit one by one until the correct 4-digit password is completed, and then press the “i” button to access power-on password enable settings interface, otherwise stay still in the password input state.



Power-on Password Entering Interface

◆Power-on Password Enable/Disable

To change power-on password enable/disable settings, press “+” or “-” button to select Y or N.

If it is Y, press the “i” button and then access power-on password modify interface,

otherwise exit the power-on password settings interface. The default value is N.

Y is power-on password enable. N is power-on password disable.



Power-on Password Disable Interface

◆ Power-on Password Change

When the display shows P3, 0000, to set new power-on password, press the “+” or the “-” button to modify the value and then press the “i” button to confirm digit one by one until the new 4-digit password is completed.

To store the new power-on password, hold the “i” button for 2s and then exit settings.

When switching the E-bike system on next time, the display will show P1, 0000, please input the new password to power on.



Power-on Password Change Interface

◆ Exit Settings

In the settings state, press the “i” button is to confirm the input. Hold the “i” button is to store the settings, and then exit the current settings. Hold the “-” button is to cancel the operating but not storing settings data, and then return to previous menu.

■ If there is no operations in one minute, the display will exit the settings state.

Recover Default Settings

dEF represents recover default settings. The default value is N.

To access recover default settings, hold both the “-” and the “i” button for 2s.

Press “+” or “-” button to choose Y or N again. N means that do not recover default settings. Y means that recovers default settings.

When it is Y, hold the “i” button for 2s to recover default settings; the display shows DEF-00 at the same time, and then return to general display state.



Recover Default Settings Interface

Quality assurance and warranty scope:

I. Warranty:

- 1) The warranty will be valid only for products used in normal usage and conditions.
- 2) The warranty is valid for 24 months after the shipment or delivery to the customer.

II. Others

The following cases do not belong to warranty scope:

- 1) The display is demolished.
- 2) The damage of the display is caused by wrong installation or operation.
- 3) The shell of the display is broken after the display is out of the factory.
- 4) The cable of the display is broken.
- 5) Beyond warranty period.
- 6) The fault or damage of the display is caused by the force majeure (e.g., fire, earthquake, etc.).

Wire connection layout

Connector wire sequence

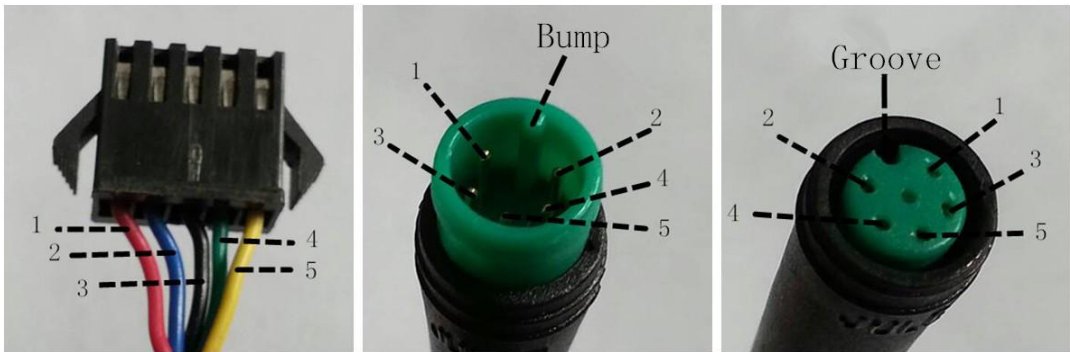

Connector to controller

display end

connection wire end to display end

Wire sequence table

| Wire sequence | Color | Function |
|---------------|------------|----------|
| 1 | Red(VCC) | + |
| 2 | Blue(K) | Lock |
| 3 | Black(GND) | - |
| 4 | Green(RX) | RX |
| 5 | Yellow(TX) | TX |

■Some products have wire connection with water-proof connectors; users can't see the color of wires in the harness.

Warnings:

1. Use the display with caution. Don't attempt to disconnect or link the connector when battery is on power.
2. Try to avoid hitting the display.
3. Don't modify system parameters to avoid parameter disorder.
4. Make the display repaired when an error code appears.

■THIS MANUAL INSTRUCTION IS A GENERAL-PURPOSE VERSION.SOME OF THE VERSIONS FOR THE DISPLAY SOFTWARE WILL BE DIFFERENT FROM SPECIFICATION TO SPECIFICATION. PLEASE ALWAYS REFER TO AN ACTUAL VERSION

Attached list 1: Error Code Definition

| Error Code | Definition |
|------------|-------------------------------|
| 21 | Current Abnormality |
| 22 | Throttle Abnormality |
| 23 | Motor Phase Abnormality |
| 24 | Motor Hall Signal Abnormality |
| 25 | Brake Abnormality |
| 30 | Communication Abnormality |

Attached list 2: PAS ratio default value table

| level PAS level Mode | 1 | 2 | 3 | 4 | 5 | 6 | 7 | 8 | 9 |
|----------------------------|-----|-----|-----|-----|-----|-----|-----|-----|-----|
| 0-3/1-3 | 50% | 74% | 92% | — | — | — | — | — | — |
| 0-5/ 1-5 | 50% | 61% | 73% | 85% | 96% | — | — | — | — |
| 0-7/ 1-7 | 40% | 50% | 60% | 70% | 80% | 90% | 96% | — | — |
| 0-9/ 1-9 | 25% | 34% | 43% | 52% | 61% | 70% | 79% | 88% | 96% |